

PRIMASONICS®



PAS 60

**Data Pack
Prima Model
PAS 60**

Safe, automated, effective prevention and removal of dry powder,
particulate build up and blockages.



● Technical Information

PRIMA PAS-60

THE MOST POWERFUL AUDIOSONIC ACOUSTIC CLEANER IN THE WORLD
Available as straight or curved options.

APPLICATION

BENEFITS

Electrostatic Precipitators

Prevents build up on plates and wires
Prevents build up on distribution plates
Eliminates build up on upper frames and walls
Eliminates the need for rappers

Filters

Increases bag life
Eliminates build up
Prevents high pressure drop

Power Generation Plant

Prevents deposit build up on heat transfer
surfaces
Eliminate steam sootblowers

Silos/Bins

Prevents ratholing and build up on vertical
surfaces
Prevents hopper bridging

Spray Dryers/Ship Holds

Prevents build up on vertical surfaces
Increases up-time

Specification:

- Frequency 60 Hz
- Sound Pressure Level 155 dB
- Air Pressure Requirement
5.2 – 6.2 bar 75 – 90 psi 515 – 620 kPa
- Air Consumption
1500 – 2260 l/min 54-80 SCFM when
sounding
- Solid Piping 25 mm/1 inch
- Flexible Piping 20 mm/0.75 inch
- Overall Height (Straight) – 3123 mm
- Overall Height (Curved) - 1841 mm

Safe, automated, effective prevention and removal of dry powder,
particulate build up and blockages.



● Technical Information

PRIMA PAS-60

THE MOST POWERFUL AUDIOSONIC ACOUSTIC CLEANER IN THE WORLD
Available as straight or curved options.

Material of Construction:

Bell Section Straight

Spun 316 Grade Stainless Steel

Bell Section Curved

Cast 316 Grade Stainless Steel

Wave Generator

Solid Machined Stainless Steel

Diaphragm

Ultra High Grade Titanium

Accessory Equipment:

- Solenoid Valve
- Individual Timer
- Automatic Timing System (PLC)
- Mounting Tube (full or part)
- Mounting Flange
- Mounting Boot
- Pressure Gauge/Regulator

Safe, automated, effective prevention and removal of dry powder, particulate build up and blockages.



● Technical Information

PRIMA PAS - 60

Specification

Fundamental Frequency: 60Hz

With a low fundamental frequency the PAS – 60 is suitable for providing effective acoustic cleaning for the largest storage applications where a large volume must be cleaned or applications with high levels of surface acoustic absorption and large volumes such as filters and boilers with large tube banks.

Sound power level: 148dB

Measured in a fully anechoic chamber with a lower frequency cut off of 40Hz

Air pressure requirement:

4.8 – 6.2 Bar 70 – 90 psi 480 – 620 Ksi

Normal plant air can be used there is no need to use expensive instrument air. For applications where oxygen may not be present nitrogen can be used.

Air consumption:

21.25l/s 45SCFM @ 5.5 bar 80psi when sounding

To calculate the average air consumption for an acoustic cleaner you must know the sounding pattern. This can be found on the final page of your operation and maintenance manual, alternatively contact Primasonics® Technical department. With a typical sounding pattern a Primasonics PAS-75 will use 1.06Nm³ per hour, this low consumption means that air receivers and the associated cost of purchase, inspection and installation can be avoided.

Materials of construction:

Wave generator: As Standard 316 Stainless Steel, EN Steel no. k.h.s DIN 1.4401 EN Steel name, X5CrNiMo17-12-2, UNS S31600

Close tolerance CNC machined to provide a good surface finish and fit. Type 316 is suitable for food and pharmaceutical uses. The addition of molybdenum within the alloy prevents specific forms of corrosion. It is also known as marine grade stainless steel due to its increased resistance to chloride corrosion. 316 stainless steel is particularly suited to harsh and corrosive operating conditions. Machining rather than casting allows a smooth surface to maximise the area of laminar air flow and boost output power.

Safe, automated, effective prevention and removal of dry powder, particulate build up and blockages.

PRIMASONICS®



PRIMA PAS - 60

Materials of construction:

Diaphragm: Grade 5 Titanium Ti-6Al-4V

Titanium Grade 1-4 is pure Titanium, the other grades are alloys. An alloy is used by Primasonics® because of the extremely high strength to weight ratio and heat resistance. As the diaphragm is the only moving part of an acoustic cleaner it must possess a high strength and resistance to fatigue failure. Grade 5 with a minimum tensile strength of 897 MPa 130(ksi) compares very favourably to Grade 1 titanium which has a minimum tensile strength of just 241 MPa. The high strength to weight ratio of 226 ($\times 10^6 \text{N.m.kg}^{-1}$) allows the diaphragm to exhibit high fatigue strength with low inertia which is well suited to periodic operation allowing the cleaner to come quickly to full power.

Materials of construction:

Horn Sections: As Standard 316 Stainless Steel, EN Steel no. k.h.s DIN 1.4401 EN Steel name, X5CrNiMo17-12-2, UNS S31600

The Acoustic Cleaner horn sections are available as standard in 316 stainless steel. In addition to the properties mentioned in the wave generator section 316 also has good oxidation resistance in intermittent service to 870°C and in continuous service to 925°C. All the horn sections are metal spun, also known as flow forming which provides a smooth internal surface to minimise losses caused by friction at the horn surface, horn surfaces are finished to a minimum of 180/1 grit /BS 1499 Gr.3B. The method of manufacture allows us to create the correct exponential expansion which avoids the edge reflections and loss of power experienced when fabricating horns from a series of cones.

While 316 grade provides excellent physical characteristics and performance for most applications other materials can be provided for specific operating conditions. We have also manufactured from 310 grade, inconel, hastalloys, and food grade polymers using a resin transfer moulding process.

Safe, automated, effective prevention and removal of dry powder, particulate build up and blockages.

PRIMASONICS®



PRIMA PAS - 60

Materials of construction:

Mountings: As Standard 304 Stainless Steel, EN Steel no. k.h.s DIN 1.4301 EN Name 304S31 UNS S30400

A very wide range of mounting options are available from Primasonics®. As standard these mountings are supplied in 304 stainless steel which has excellent corrosion resistance in a wide range of atmospheric environments and many corrosive media. Heat resistance is provided with good oxidation resistance in intermittent service to 870°C and in continuous service to 925°C. Grade 304 also has outstanding welding characteristics even when welded to dissimilar materials making it very suitable for a wide range of installations from part of a O.E.M installation to a retrofit on existing plant. Another advantage of 304 grade is that post-weld annealing is not required when welding thin sections.

Painting

Due to the use of high quality materials painting is not normally required, this removes the danger of material contamination due to paint flakes entering the application and avoids maintenance time required for periodic repainting. For specific applications however a range of surface finishes can be applied ranging from simple painting to match a company colour scheme to powder coating for chemical resistance and boron nitride coatings for the most challenging high temperature applications.

Control Equipment.

Acoustic Cleaners are controlled by allowing compressed air to flow through the Wave Generator when a solenoid valve is opened. Primasonics solenoid valves can be controlled either through dedicated, integrated timer units, from the clients central or local control system or from dedicated control panels which can be supplied by Primasonics. In all cases the below specifications apply.

Minimum IP Rating 65.

Operating Voltages AC 24, 110, 230V. Frequency 50, 60 Hz. DC 24V

Response time 50-500 ms

Power Consumption Inrush 36VA at DN13 Hold 14VA/8 W at DN 13.

Electrical Connection. Cable plug DIN 43 650 A.

Duty Cycle 100% continuously rated.

Body Materials. Brass or Stainless Steel

Safe, automated, effective prevention and removal of dry powder, particulate build up and blockages.

● PRIMASONICS® AUDIOSONIC™ ACOUSTIC CLEANER
DIMENSIONAL DRAWING

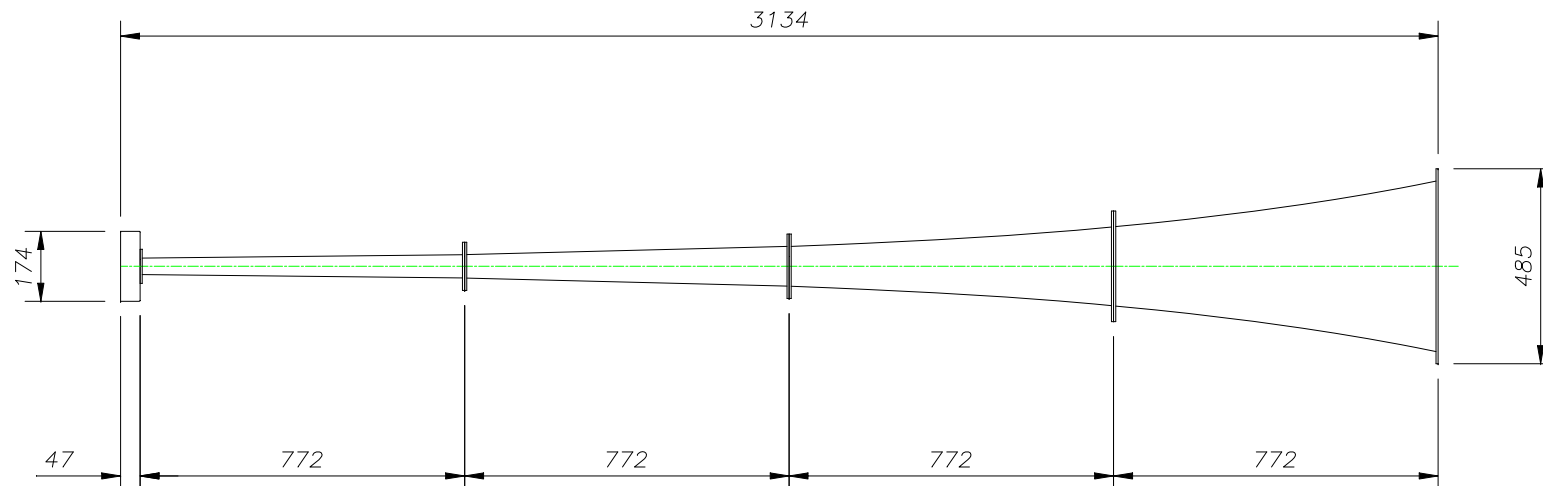

Drawing N° - AS060
AudioSonic™ Range – Model PAS 60 S

Safe, automated, effective prevention and removal of dry powder, particulate build-up and blockages

● PRIMASONICS® AUDIOSONIC™ ACOUSTIC CLEANER
DIMENSIONAL DRAWING

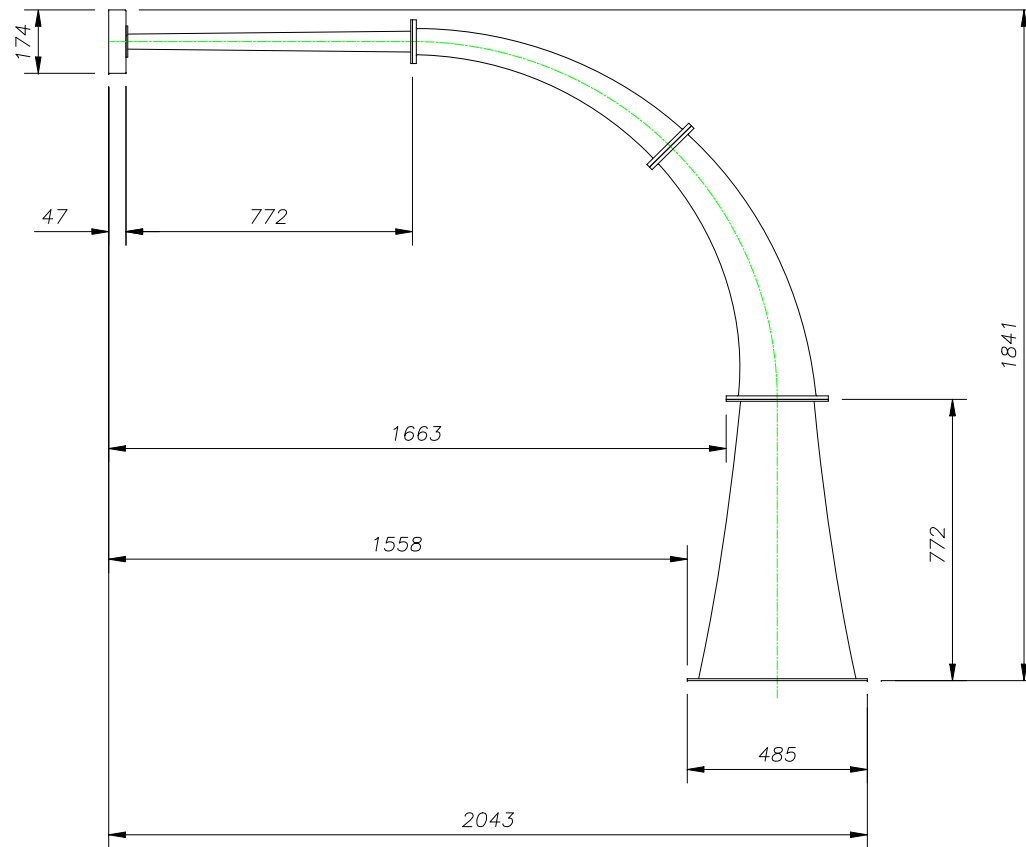

Drawing N° - AS071
AudioSonic™ Range – Model PAS 60 C

Safe, automated, effective prevention and removal of dry powder, particulate build-up and blockages

**PRIMASONICS® AUDIOSONIC™ ACOUSTIC CLEANER
GENERAL PIPING ARRANGEMENT
(PRIMASONICS PART NUMBER IN BRACKETS)**

AIR PRESSURE REQUIREMENT
4.8-6.2 bar 70-90 psi 480-620 kPa
AIR CONSUMPTION
1130-2260 l/min 40-80 SCFM when sounding

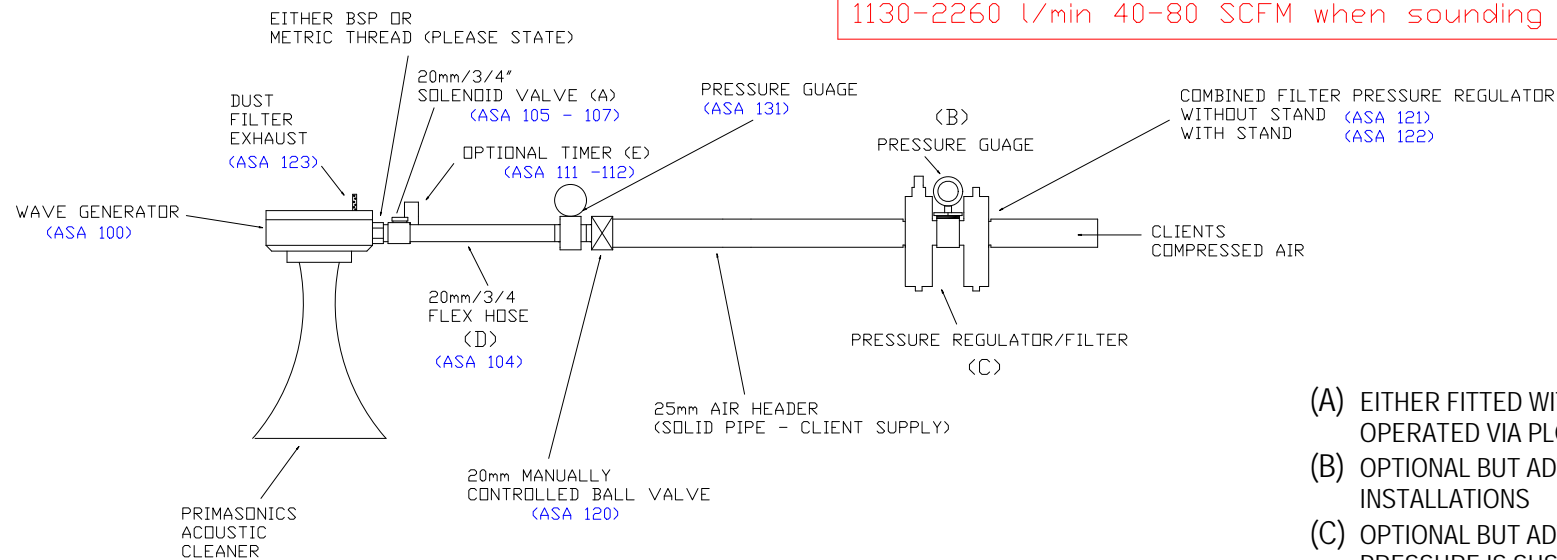

- (A) EITHER FITTED WITH AN INDIVIDUAL TIMER OR OPERATED VIA PLC (MULTI INSTALLATION)
- (B) OPTIONAL BUT ADVISED IN REMOTE INSTALLATIONS
- (C) OPTIONAL BUT ADVISED IF AIR QUALITY OR PRESSURE IS SUSPECT
- (D) MAXIMUM ADVISED LENGTH 4M, PREFERRED 2M
- (E) OPTIONAL BUT REQUIRED IF NO PLC CONTROL
- (F) OPTIONAL BUT ADVISED TO ISOLATE COMPRESSED AIR

DRAWING N° PAS-G001

Safe, automated, effective prevention and removal of dry powder, particulate build-up and blockages